



Via ex Salaria per L'Aquila km 91+500, 02010
Nucleo Industriale di Rieti-Cittaducale (Ri)
tel 0746.606020/fax 0746.606988/handy 335.5741546
e-mail: commerciale@pezzopanemanufattisrl.it

Emissione: 17/01/17

DATA AGGIORNAMENTO: 06/02/2017

Materiali: Slump Cls: S1

NOME FILE: 170206 - Cigli

Scala disegno: Varie Foglio 1/1

PEZZOPANE MANUFATTI S.r.l.

VIBROPRESSI

12x25x100

CARATTERISTICHE COMMERCIALI	
PESO CAD KG	68
PESO IMBALLO Q.LI	14,30
PORTATA MOTRICE	160
PORTATA AUTOTRENO	440

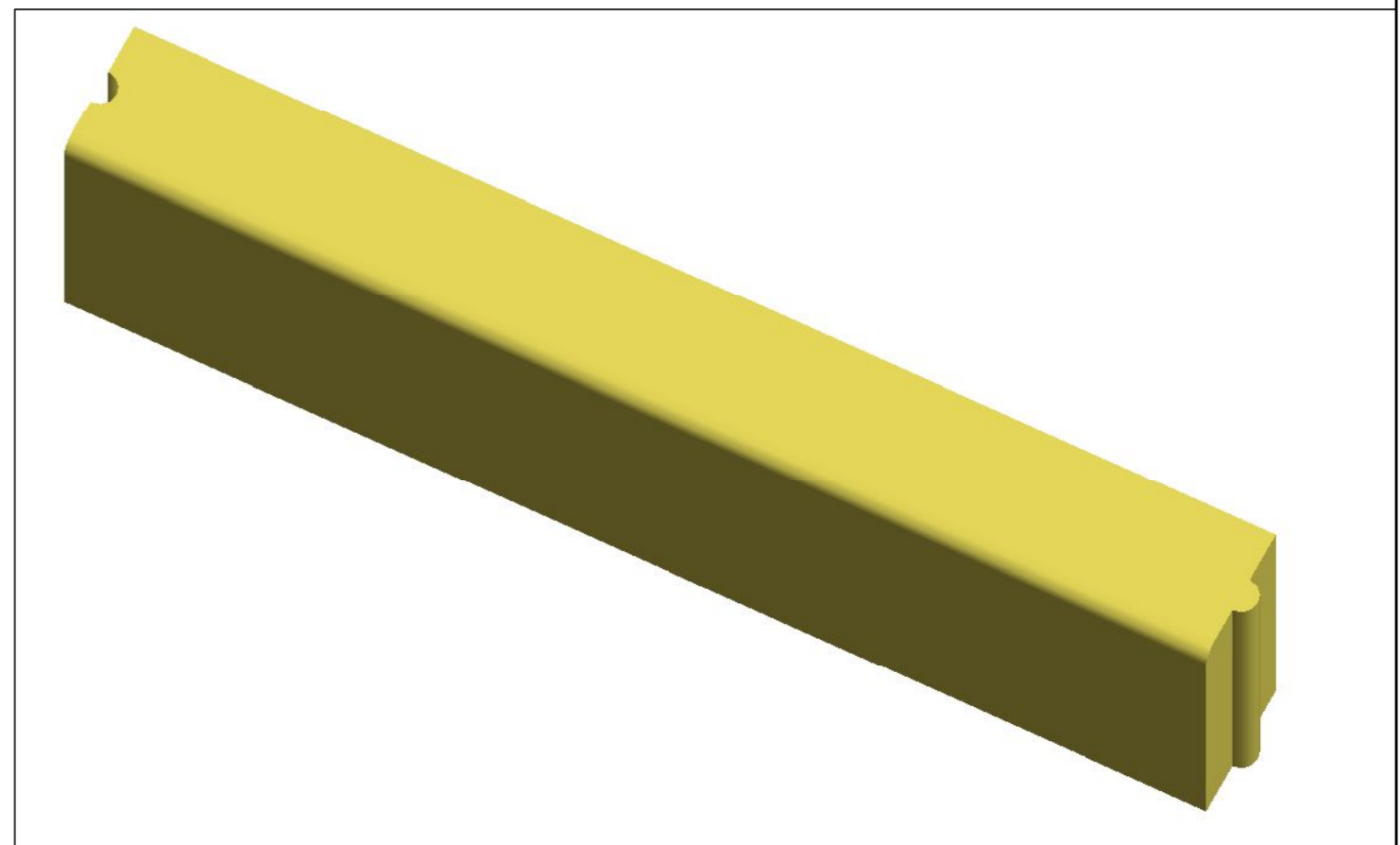
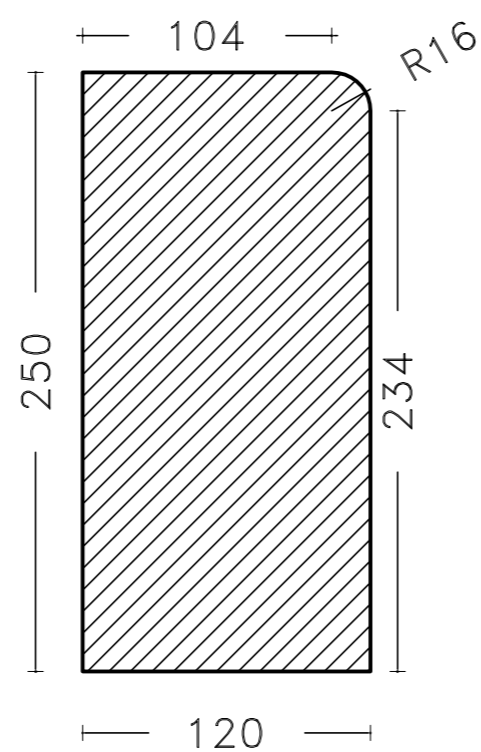

8x25x100

A RICHIESTA

CARATTERISTICHE COMMERCIALI	
PESO CAD KG	43
PESO IMBALLO Q.LI	15,50
PORTATA MOTRICE	240
PORTATA AUTOTRENO	690

